



VHF Transceiver

AR 4201 - ()

INSTALLATION AND OPERATION

Serial No.: 1000 upwards

Issue 1 15 December 1995
Revision 1 22. May 1996
Revision 2 15 December 1998

Baden Airpark • B 108
D-77836 Rheinmünster Phone +49(0)7229/305-0
E-Mail info@becker-avionics.de or support@becker-avionics.de

23-10-01

December 15/98

SERVICE BULLETIN LIST

SERVICE BULLET. NO.	MOD. STATE IDENT.	INSERTED BY	DATE	SERVICE BULLET. NO.	MOD. STATE IDENT.	INSERTED BY	DATE

BECKER

AVIONIC SYSTEMS

INSTALLATION AND OPERATION

AR 4201 - ()

RECORD OF REVISIONS

REV. NO.	ISSUE DATE	INSERTED		REV. NO.	ISSUE DATE	INSERTED	
		DATE	BY			DATE	BY
	1	15.12.95	1000				
	1	22.05.96	1500	1			
	1	15.12.98	4900	2			

BECKER
AVIONIC SYSTEMS
 INSTALLATION AND OPERATION
 AR 4201 - ()

LIST OF EFFECTIVE PAGES

<u>SUBJECT</u>	<u>PAGE</u>	<u>DATE</u>	<u>SUBJECT</u>	<u>PAGE</u>	<u>DATE</u>
Titel page		Dec. 15/98		3- 9	Dec. 15/95
				3-10	Dec. 15/98
Service bulletin list	1	Dec. 15/95		3-11	Dec. 15/95
				3-12	DEC.15/98
Record of revisions	1	Dec. 15/98		3-13	Dec. 15/95
				3-14	Dec. 15/95
				3-15	Dec. 15/95
				3-16	Dec. 15/95
				3-17	Dec. 15/95
				3-18	Dec. 15/98
List of effective page	1	Dec. 15/98		3-19	Dec. 15/95
	2	Dec. 15/98		3-20	Dec. 15/95
Table of contents	1	Dec. 15/95			
Introduction	1	Dec. 15/95			
General description	1-1	Dec. 15/95			
	1-2	Dec. 15/95			
	1-3	Dec. 15/95			
	1-4	Dec. 15/95			
	1-5	Dec. 15/95			
	1-6	Dec. 15/95			
	1-7	Dec. 15/95			
	1-8	Dec. 15/95			
	1-9	Dec. 15/95			
	1-10	blank			
Installation	2-1	Dec. 15/95			
	2-2	Dec. 15/95			
	2-3	Dec. 15/95			
	2-4	Dec. 15/95			
	2-5	Dec. 15/95			
	2-6	Dec. 15/95			
	2-7	Dec. 15/95			
	2-8	Dec. 15/95			
	2-9	May. 22/96			
	2-10	Dec. 15/95			
Operation	3-1	Dec. 15/95			
	3-2	Dec. 15/95			
	3-3	Dec. 15/98			
	3-4	Dec. 15/98			
	3-5	Dec. 15/95			
	3-6	Dec. 15/95			
	3-7	Dec. 15/95			
	3-8	Dec. 15/95			

BECKER
AVIONIC SYSTEMS

INSTALLATION AND OPERATION

AR 4201 - ()

TABLE OF CONTENTS

	<u>Page</u>
INTRODUCTION	1
GENERAL DESCRIPTION	1-1
INSTALLATION	2-1
OPERATION	3-1

BECKER
AVIONIC SYSTEMS
INSTALLATION AND OPERATION
AR 4201 - ()

INTRODUCTION

1. General

This manual describes the AR 4201 - () VHF transceiver upwards serial number 1000.

2. Manufacturer

The VHF transceiver was developed and manufactured, and is serviced, by

Becker Flugfunkwerk GmbH
Airport
P.O. Box 34
D-76549 Hügelsheim

Germany

Telephon: +49 (0) 07229 / 305-0
Telefax: +49 (0) 07229 / 305-217

3. Layout of manual

The manual is divided into seven sections. Section 1 contains the general description of the VHF transceiver and gives the technical data. Section 2 describes the installation instructions and Section 3 the operation of the unit.

4. Revisions to the manual

All the incorporated revisions to the manual are listed in sequence on the front page "Record of Revisions".

BECKER
AVIONIC SYSTEMS
INSTALLATION AND OPERATION
AR 4201 - ()

Table of contents

General description		Page
1.	Purpose of equipment	1-1
2.	General description	1-1
3.	Technical data	1-3
4.	Software	1-5
5.	Approval	1-5
6.	Environmental Qualification Form	1-6
7.	Accessories	1-7
8.	Scope of delivery	1-8
Fig. 1-1	Standard accessories AR 4201 - ()	1-9

GENERAL DESCRIPTION

1. Purpose of equipment

The VHF transceiver enables voice communication on 760 channels in the 118.000 MHz to 136.975 MHz range with a channel spacing of 25 kHz. The VHF transceiver is designed with sufficient mechanical strength to enable it to be fitted in an aircraft without any limitations. There is no restriction within the verified environmental classes on fitting in the instrument panel, or fixed mounting in the fuselage, of all types of aircraft including helicopter.

2. General description

- A. The VHF transceiver has been developed as a single block unit. The dimensions correspond to the standard instrument diameter of 58 mm (2 1/4 inches). Mounting is by means of four screws (rear panel mounting). All controls and indicators are located on the front panel. The rear of the unit holds the equipment connector and the antenna socket.
- B. After it is switched on, the unit performs a self test. All segments of the display flash during the self test. If faults are detected, the LCD (liquid crystal display) displays a fault code for approximately five seconds. The VHF transceiver then automatically activates the mode set before it was switched off.
- C. The VHF transceiver is fitted with a single superheterodyne receiver. A squelch (muting) circuit suppresses transmitters or disturbances below a certain field strength. The switching threshold can be set. The squelch function can also be switched off.
- D. The transmitter is designed to be wideband over the 118.000 MHz to 136.975 MHz range. The transmitter output power is ≥ 5 Watt. The sidetone is automatically switched to the headphone output during transmission.
- E. The oscillator frequency of the receiver and the the transmitting frequency of the transmitter are generated by a VCO (voltage controlled oscillator). This is monitored by a digital frequency evaluation circuit. This digital frequency processing operates in conjunction with a microprocessor.
- F. The microphone inputs are designed for both dynamic and standard microphones. The inputs are connected to a dynamic volume compressor which keeps the modulation voltage constant over a wide input voltage range.
- G. The frequency indication is by means of a liquid crystal display (LCD). The required operating frequency is set using the MHz and kHz frequency selector switches. The MHz rotary switch engages at 1 MHz steps and the kHz rotary switch at 25 kHz steps. The VHF transceiver also contains a memory device for storing 99 different frequencies which remain stored even with the unit switched off without an auxiliary battery.

- H. The VHF transceiver also contains a monitoring stage for the supply voltage which is activated when the VHF transceiver is switched on. If the supply voltage drops below 10.5 V, the segments of the LCD begin to flash.
- I. In the mode 3, the supply voltage and temperature is displayed in the bottom line of the LCD.
- J. Aircraft internal communication is possible in the IC (intercom) mode. Activation is by means of an external IC button (or switch) which is to be connected to the equipment connector.
- K. The AF auxiliary input enables AF signal switching of auxiliary units in the aircraft. The switched AF signals can, however, only be monitored in the reception mode.
- L. If illumination of the LCD is required, this can be connected either directly to the supply voltage or via a dimmer.
- M. The scan function can be switched on in the service mode and called up in mode 2. The active frequency is shown in the top line of the display and the bottom line shows the associated storage channel with the preset CS. In the scanning mode the stored frequencies in the storage channels are scanned in succession at 200 ms intervals. When an evaluatable reception signal is found, the VHF transceiver remains on this frequency until an evaluatable reception frequency is no longer present. It then begins to scan all the stored frequencies again in 200 ms intervals. In the service mode, the hold time between the end of an evaluatable signal and the continuation of the scanning of the next channels can be set to between 0 and 60 seconds.

N. Special functions

VHF transceiver contains some special functions which can be set in the service mode.

- | Adjustment of volume IC, sidetone, AF auxiliary and the sensitivity of dynamic microphone.
- | The switch-on threshold of the squelch can be set in the service mode.
- | The frequency setting can be inhibited. The VHF transceiver then operates only on the frequencies stored in the storage channels.
- | The storage of frequencies in the storage channels can be inhibited.
- | Stored frequencies can be erased.
- | Access to the service mode can be interlocked with a 4-digit password.
- | The scan function can be switched on.

BECKER
AVIONIC SYSTEMS
INSTALLATION AND OPERATION
 AR 4201 - ()

O. Options

- (1) In the mode 3, a temperature in °C or °F can be measured via a temperature sensor which can be externally connected, and this temperature is displayed in the bottom line of the LCD. The choice between °C and °F is made in the service mode.

3. Technical data

A. General data

Nominal supply voltage	13.75 V.d.c.
Supply voltage range	12.4 V to 15.1 V
Emergency operation (10.0 V)	Good intercom
Power consumption at 13.75 V without panel lighting	
"Standby" reception mode	≤ 70 mA
Reception mode	≤ 500 mA
Transmission mode	≤ 2.5 A
Panel lighting	13.8 V.d.c/40 mA
Frequency range	118.000 MHz to 136.975 MHz
Number of channels	760
Channel spacing	25 kHz
Storage temperature range	-55°C to +85°C
Operating temperature range as per EUROCAE/RTCA ED-14C/DO-160C	-20°C to +55°C short-time +70°C
Operating altitude as per EUROCAE/RTCA ED-14C/DO-160C	50 000 ft
Vibration as per EUROCAE/RTCA ED-14C/DO-160C	Cat. NM
Humidity as per EUROCAE/RTCA ED-14C/DO-160C	Cat. A/+50°C: 95%, 48 h
Dimensions	
Front panel	60.6 mm x 60.6 mm
Depth of unit without cable connector	192 mm
Weight	0.67 kg
internal Fuse	5 A

BECKER
AVIONIC SYSTEMS
 INSTALLATION AND OPERATION
 AR 4201 - ()

B. Receiver data

Type of receiver	Single superhetrodyne receiver
Sensitivity	$\leq 5 \mu\text{V}$ EMF for 6 dB = SINAD (mod. 1000 Hz/30%)
IF bandwidth	$\geq \pm 8$ kHz at 6 dB attenuation
Selectivity	≥ 40 dB at ± 17 kHz ≥ 60 dB at ± 25 kHz
Squelch	Can be adjusted and switched off
AGC characteristic for 5 μV to 100 mV EMF	≤ 6 dB
Distortion m = 85%	$\leq 15\%$
Audio frequency response relative to 1000 Hz	≤ 6 dB 350 Hz to 2500 Hz ≥ 18 dB at 4000 Hz
Intermediate frequency	21.4 MHz
Rated output for speaker operation	at 13.75 V nominal operating voltage ≥ 3 W at 4 Ω at 10.0 V operating voltage (emergency mode) ≥ 1.5 W at 4 Ω
with headset connected	at 13.75 V nominal operating voltage ≥ 100 mW at 600 Ω at 10.0 V operating voltage (emergency mode) ≥ 30 mW at 600 Ω
Audio auxiliary input adjustable (regardless of volume)	1 V to 8 V at 600 $\Omega \pm 10\%$

C. Transmitter data

Transmitter output at 50 Ω	≥ 5 W
at 10.0 V operating voltage (emergency mode)	≥ 2 W
Frequency tolerance	≤ 15 ppm
Duty cycle	1:4 (Min)
Type of modulation	A3E amplitude modulation
Modulation factor	$\geq 70\%$ to $\leq 99\%$ (dynamic compressor)

Distortion at 70% modulation	≤ 15%
Modulation bandwidth	350 Hz to 2500 Hz
Frequency response	-6 dB (relative to 1 kHz/0 dB)
Input voltage (m = 70%)	
Dynamic microphone	typ. 2 mV symmetrical 150 Ω (dynamic compressor)
Standard microphone	typ. 100 mV 100 Ω (dynamic compressor)
FM deviation with modulation m = 70% f = 1.25 kHz	≤ 3 kHz
Sidetone	true, adjustable
Automatic shutdown on short circuit of transmit button	after 2 mins of continuous transmission, the transmitter shuts down. Activated by releasing the transmit button and re-pressing.

D. Additional functions

Digital voltmeter (Supply voltage display)	7 V to 15 V d.c. ± 0.1 V
Digital thermometer with external sensor (option)	-20°C to + 55°C

4. Software

The frequency processing, frequency storage and frequency display of the AR 4201 - () are controlled by microprocessors. The software was classified as Category "ESSENTIAL" Level 2 in agreement with the EUROCAE/RTCA Document ED12A/DO-178A.

5. Approval

Regulations

JTSO - 2C37d, ED-23A, Equipment Class 4
JTSO - 2C38d, ED-23A, Equipment Class C
EUROCAE/RTCA ED-14C/DO-160C
EUROCAE/RTCA ED-12A/DO-178A
FTZ 17T R2010

6. Environmental Qualification Form

The following performance standards under environmental test conditions have been established in accordance with the procedures set forth in EUROCAE/RTCA Document No. ED-14C/DO-160C.

Environmental condition	ED - 14C DO - 160C	Category	Performance
Temperature	4.0	D1	
Low operating temperature	4.5.1		- 20° C
Low ground survival (storage temperature)			- 55° C
High short-time operating temperature	4.5.2		70° C
High operating temperature	4.5.3		+ 55° C
High ground survival (storage) temperature			85° C
Min. operating pressure (equivalent altitude)	4.6.1		50,000 ft.
Temperature variation	5.0	B	
Humidity	6.0	A	48 hrs at up to 50° C and 95% relative humidity
Shock :	7.0		
Operational shocks	7.2		11 ms at 6 G for all three dimensional axes
Crash safety shocks	7.3		11 ms at 15 G for all three dimensional axes
Vibration	8.0	MN	
Magnetic effect	15.0	Z	Deflection of 1° of compass at a distance of ≥ 30 cm
Power input variation	16.0	B	The equipment functions on a 10-volt emergency power supply
Resistance to voltage spikes on equipment power leads	17.0	A	
Audio-frequency conducted susceptibility	18.0	B	
Susceptibility to induced magnetic and electric • fields at 400 Hz	19.0	A	
Radio-frequency interference susceptibility	20.0	T	
Spurious RF emissions	21.0	A	

BECKER
AVIONIC SYSTEMS
INSTALLATION AND OPERATION
AR 4201 - ()

7. Accessories

Unit connection

Cable socket	Stock No. 725.021-277
Connector housing	Stock No. 775.479-277
Antenna plug	Stock No. 725.706-277

Antennas

VHF rod antenna with BNC connector 1A001	Stock No. 267-007-952
VHF-COMM bonded antenna 1A005 for GRP aircraft	Stock No. 358.762-952

Transmit button

Control column switch with 1.5 m long connecting cable US070	Stock No. 431.011-950
Control column switch, 10 mm, US 509	Stock No. 481.556-278

Microphones

Swan neck microphone, PM004	Stock No. 267.163-951
Microphone socket, 5-pin 1SB039	Stock No. 724.939-277

Headset and speaker

Speaker 4 Ohm, 4 W without housing, 12 cm dia.	Stock No. 710.733-353
Speaker and housing, 4 Ohm, 4 W	Stock No. 759.643-951
Headset, dynamic microphone	Stock No. 860.557-951
230 Ohm headphone, 550 Ohm (parallel) with diode plug, 180 1PH028	

Jack 3-pin PJ 68 1SB006	Stock No. 724.661-277
Jack 2-pin PJ 55 1SB004	Stock No. 724.645-277

IC switch

IC switch with 1US071 connecting cable	Stock No. 431.028-950
--	-----------------------

1PL042 speaker junction	Stock No. 879.312-951
-------------------------	-----------------------

AR4201-() cable set If a cable set is used, a cable socket and connector housing are not necessary 1K042	Stock No. 877.476-950
--	-----------------------

AR 3201-()/AR 4201-() adaptor 1AD042	Stock No. 877.522-950
--------------------------------------	-----------------------

Temperature sensor 1K043	Stock No. 878.170-278
--------------------------	-----------------------

Connector set 1SS042	Stock No. 879.304-954
----------------------	-----------------------

Manual Installation and Operation	Stock No. 894.036-071
-----------------------------------	-----------------------

Manual Maintenance and Repair (Components maintenance manual)	Stock No. 894.044-071
--	-----------------------

BECKER
AVIONIC SYSTEMS
INSTALLATION AND OPERATION
AR 4201 - ()

8. Scope of delivery

AR 4201-() VHF transceiver

Stock No. 868.541-910

4 screws

Stock No. 868.590-203

Operating instructions

Stock No. 877.689-071

BECKER

AVIONIC SYSTEMS

INSTALLATION AND OPERATION

AR 4201 - ()

ACCESSORIES FOR AR4201-()

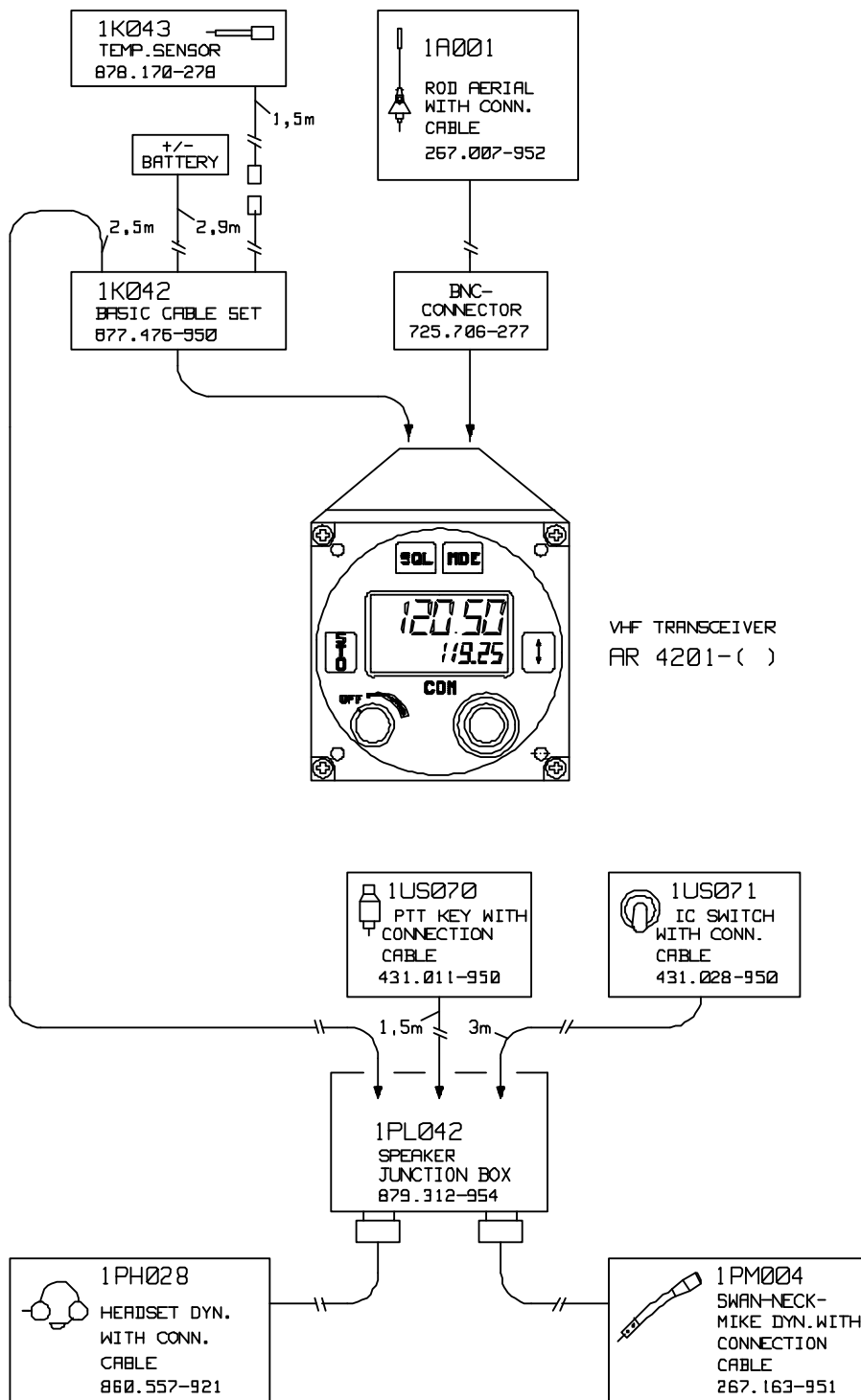

Fig. 1-1 Standard accessories AR 4201 - ()

BECKER
AVIONIC SYSTEMS
INSTALLATION AND OPERATION
AR 4201 - ()

INTENTIONALLY BLANK

BECKER
AVIONIC SYSTEMS
INSTALLATION AND OPERATION
AR 4201 - ()

Table of contents

INSTALLATION		Page
1.	General	2-1
2.	Testing before installation	2-1
3.	Mechanical installation	2-1
4.	Installation wiring	2-2
5.	Testing after installation	2-8
Fig. 2-1	Interwiring panel lighting	2-3
Fig. 2-2	Internal automatic cut-out	2-4
Fig. 2-3	Mounting dimensions VHF transceiver	2-5
Fig. 2-4	Interwiring of the VHF transceiver with dynamic mike	2-6
Fig. 2-5	Interwiring of the VHF transceiver with standard mike	2-7
Fig. 2-6	Interwiring AR 4201 - () with speaker junction	2-8

BECKER
AVIONIC SYSTEMS
INSTALLATION AND OPERATION
AR 4201 - ()

INSTALLATION

1. General

The installation of the VHF transceiver depends on the type of aircraft and its equipment. Therefore, only general information can be given in this Section.

2. Testing before installation

A. General

Before installing the VHF transceiver in an aircraft, inspect the unit for signs of transport damage.

B. Visual examination

Before commissioning, visually examine the unit paying particular attention to the following defects :

- (1) Dirt, dents, scratches, corrosion or broken attaching parts, damaged paintwork on housing, parts of the housing and panel.
- (2) Dirt or scratches on the identification plate, front panel, LCD or inscriptions.
- (3) Dirt, bent or broken pins, displaced inserts of plugs and sockets.
- (4) Dirt and mechanical damage to pushswitches and operating knobs.

3. Mechanical installation

A. Mechanical installation of VHF transceiver.

The VHF transceiver is designed for installation in the instrument panel of an aircraft. It is constructed for mounting behind the panel. The circular cutout and the mounting holes are to be drilled in accordance with the small instrument size. The mounting point shall be at least 30 cm from the aircraft magnetic compass, to avoid any interference to the magnetic compass by the Transceiver. The necessary dimensions are given in Fig. 2-3. Attachment is by means of four screws, which are included in the delivery.

B. Mechanical installation of a temperature sensor

The VHF transceiver enables temperatures in the -20°C to +55°C range to be displayed, with the aid of the fitted measuring device and the connection of an external temperature sensor. The location of the mounting of the temperature sensor depends on the particular purpose and local conditions. The wiring diagram is shown in Fig. 2-4. A twisted, screened cable should be used.

BECKER
AVIONIC SYSTEMS
INSTALLATION AND OPERATION
AR 4201 - ()

4. Installation wiring

A. General

The installation wiring diagrams are shown in Fig. 2-4 - 2-6.

NOTES :

- (1) Use only cable which is fit for use in aircraft (self extinguishing).
AWG 20 for power supply and AWG 22 for other cables.
- (2) Fit rubber sleeves over the solder joints on the equipment connector.
- (3) Protect the power supply with a 5 A fuse or circuit breaker.

- NOTE : The VHF transceiver is protected internally by a 5 A automatic cut-out.

- (4) Type-specific cable harnesses are also available for the aircraft wiring (details from manufacturing works).
- (5) No HF cables should be included in the cable harnesses of the system and the routing of connecting cables alongside cables which carry audio power or pulses should also be avoided.
- (6) Carefully check the wiring before switching on the unit and check particularly that (+) and (-) have not been reversed.

B. Microphone connection

The VHF transceiver enables a maximum of two dynamic microphones and two standard microphones (d.c. supply) to be connected at the same time. A symmetrical input transformer with an impedance of 150 Ohm is fitted at the input of the dynamic microphone.

Note: The dynamic mike input sensitivity can be changed in the service mode (SF16).

Note: When the STD mike input is used, we strongly recommend to set the sensitivity of the dynamic mike input to zero using SF16 of the service mode. This measure will prevent disturbances from the dynamic input.

BECKER
 AVIONIC SYSTEMS
 INSTALLATION AND OPERATION
 AR 4201 - ()

C. Speaker connection

A 4 to 8 Ohm speaker can be connected to audio output P1- 1AF-asym.

CAUTION : The magnetic field of a speaker influences the magnetic compass. When choosing the mounting point, a minimum distance of 1.3 m must be maintained between the speaker and the magnetic compass.

D. Headphone connection

Up to two headphones with an impedance of 600 Ohm can be connected to the audio output P1 - 2,3 AF-HI/LO.

E. Intercom mode "IC connection".

The intercom mode is designed for aircraft with a high noise level and assumes operation using headsets. Additional wiring on the equipment connector with an IC switch is necessary (refer to Fig. 2-4 - 2-6).

The normal R/T communication takes place with the IC switch in the OFF position. When the IC switch is set to ON, R/T communication can be carried on as before but intercommunication is also possible between two crew members. The IC is switched off during transmission.

F. Panel lighting

The VHF transceiver is fitted with panel lighting. It is to be connected to the aircraft external power supply via the aircraft wiring at terminal P1 23(+)/10(-) or to a dimmer control (refer to the following illustration). For aircraft without an external power supply, the lighting power should be supplied via a separate lighting switch to save power.

CAUTION : The lighting is not switched off when the unit is switched off (ON/OFF switch).

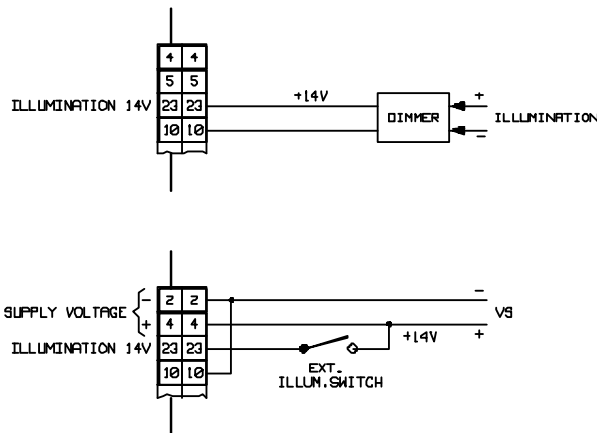

Fig. 2-1 Interwiring panel lighting

BECKER
AVIONIC SYSTEMS
INSTALLATION AND OPERATION
AR 4201 - ()

G. "Auxiliary" audio input

The AF-AUX (P1/4) auxiliary audio input enables the switching of audio signals from other equipment in the aircraft. The switched-in audio signals can, however, only be monitored in the reception mode. The facility to switch two units together will be used particularly in those aircraft which are fitted with an Transceiver and an NAV receiver. An audio input voltage of 1 to 8 V, 600 Ohm is necessary for modulation of the audio amplifier (can be adjusted in the "Service" mode).

H. Internal automatic cut-out

The released automatic cut-out is reactivated by mean of a suitable object.

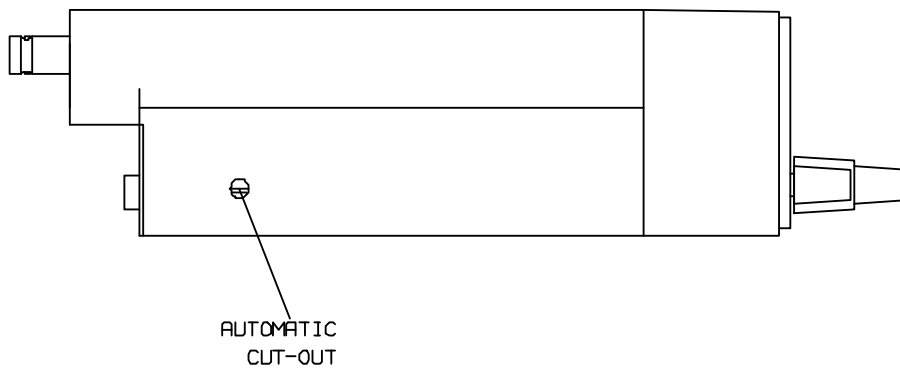

Fig. 2-2 Internal automatic cut-out

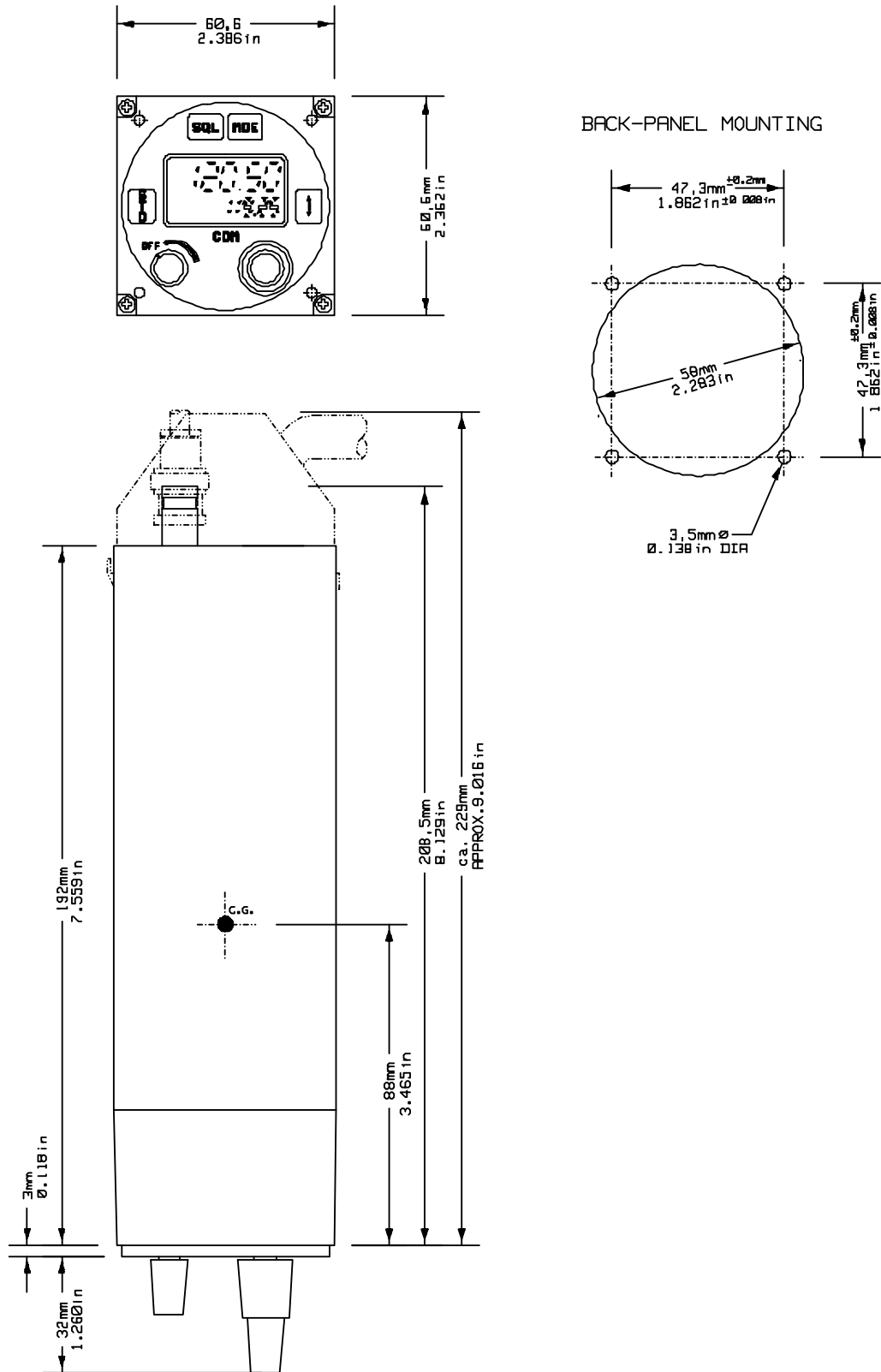

Fig. 2-3 Mounting dimensions VHF transceiver

BECKER AVIONIC SYSTEMS

INSTALLATION AND OPERATION

AR 4201 - ()

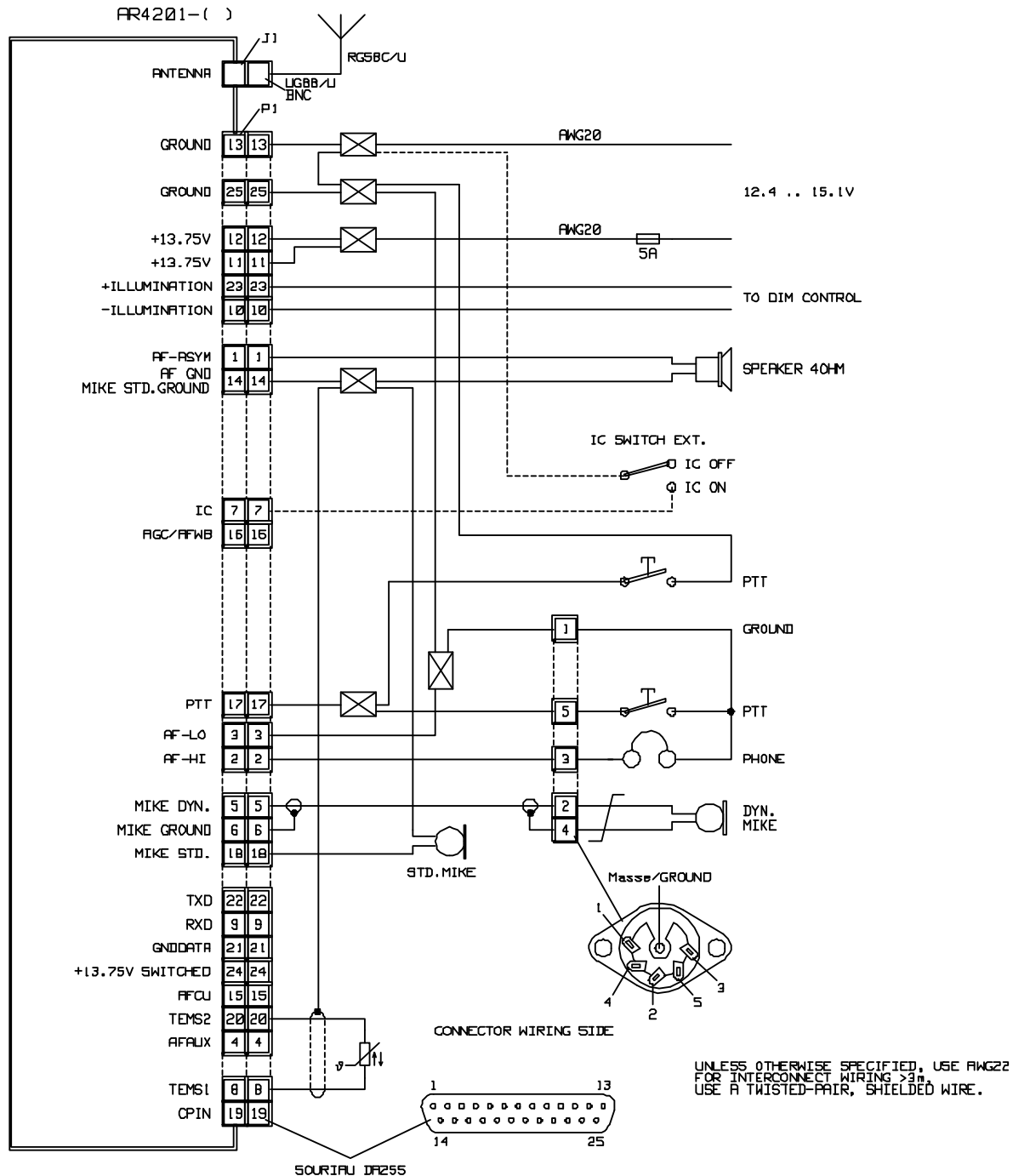

Fig. 2-4 Interwiring of the VHF transceiver with dynamic mike

BECKER

AVIONIC SYSTEMS

INSTALLATION AND OPERATION

AR 4201 - ()

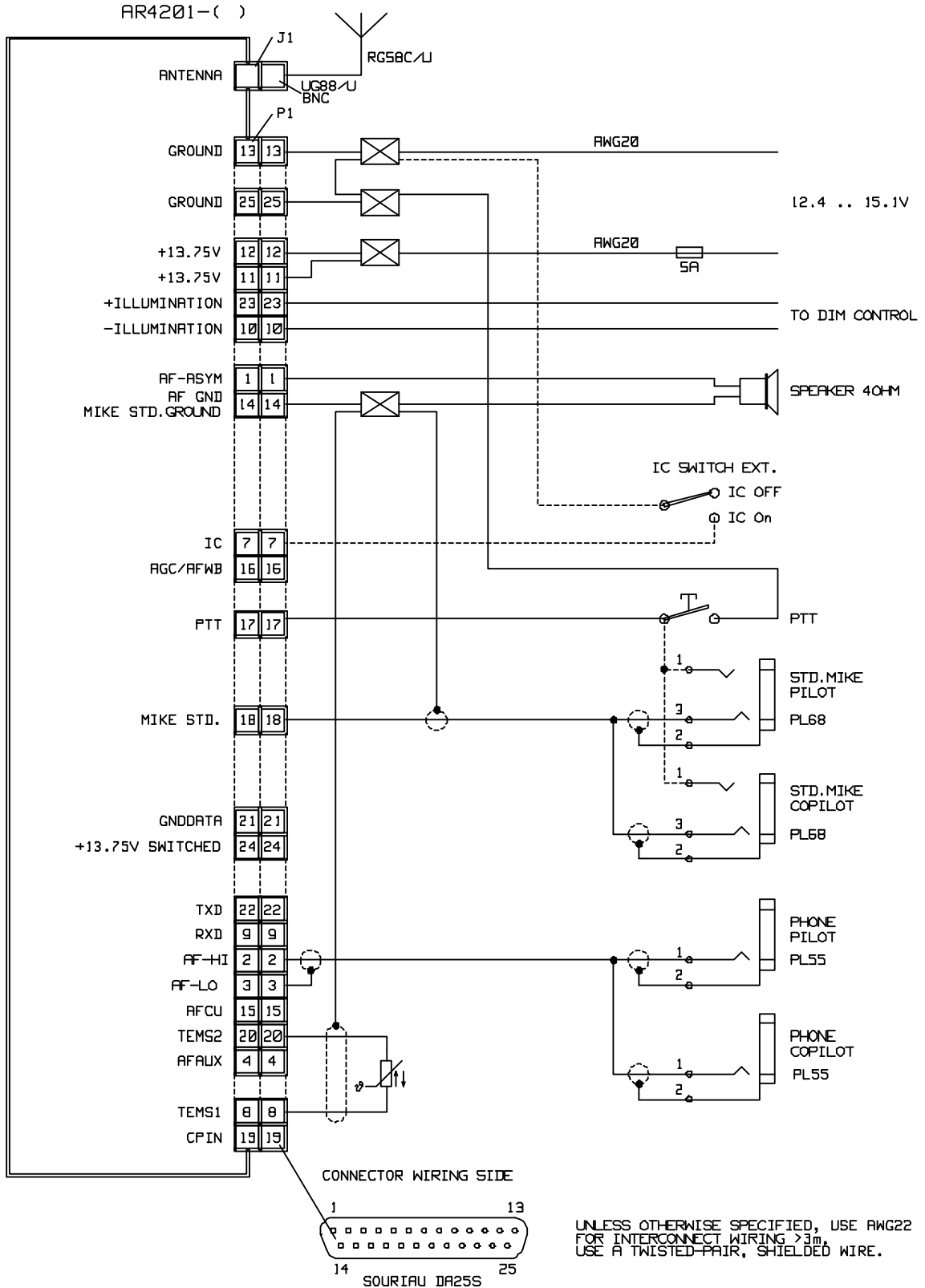

Fig. 2-5 Interwiring of the VHF transceiver with standard mike

BECKER
AVIONIC SYSTEMS
INSTALLATION AND OPERATION
AR 4201 - ()

5. Testing after installation

A. Ground test with engine shut down.

- (1) After installation of the unit, measure the antenna tuning between the base of the antenna and the antenna connecting cable using a VHF reflection-coefficient meter (voltage standing wave meter).
- (2) The VSWR (voltage standing wave ratio) over the complete frequency range of the unit shall be within 3:1. If this matching value is incorrect, this indicates a mismatch, caused for example by an incorrect or unsatisfactory counterpoise, a cable with an impedance which deviates significantly from 50 Ohm or an incorrectly tuned antenna.
- (3) After the antenna measurement, check the readability by carrying out a speech test with a ground station.

B. Ground test with engine running.

- (1) With the engine running at cruising speed check that the aircraft power supply is within the permissible tolerances at approximately 14 V.
- (2) When performing the succeeding speech test, ensure that the distance from the ground station is as great as possible, at least 100 m. With the engine at cruising speed, the cabin noise of the aircraft should be only slightly transmitted and communication should be clear and distinct. Hold the microphone close to the lips when speaking.
- (3) Switch on the aircraft intercom using the IC switch (if fitted) and carry out a speech test with the engine running at cruising speed. If necessary, adjust the IC volume (refer to the service mode in the operating instructions (section 3)).
- (4) Switch on the squelch switch and check the squelch function. The point at which the squelch operates is set in the service mode (refer to operating instructions, section 3).
- (5) The sidetone volume can be adapted to the cabin noise in the aircraft. If necessary, adjust the sidetone volume (refer to the service mode in the operating instructions (section 3)). When using the loudspeaker, the sidetone should be adjusted so that no acoustic feedback occurs.

BECKER
AVIONIC SYSTEMS
INSTALLATION AND OPERATION
AR 4201 - ()

INTENTIONALLY BLANK

Table of contents

OPERATION		Page
1.	Controls and indicators	3-1
2.	Meaning of symbols on controls and indicators	3-1
3.	Operating instructions	3-3
4.	Safety instructions	3-19

1. Controls and indicators

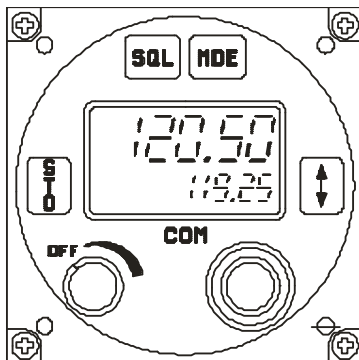

2. Meaning of symbols on controls and indicators

A. Controls



Function key

Selection of mode



Exchange key

Mode 1:
Exchange of preset frequency
and active frequency.

Mode 3:
Switching between temperature
and operating voltage indication.



Store key

Storage of set frequency or in
Mode 2 a change between the
channel selection mode and scan
mode.



Squelch key

Switching the squelch on or off.
When the key is pressed, the
bottom line indicated ON or OFF



Frequency selector
switch

Switching the indicated
frequency in 1 MHz (outer rotary
switch) steps or the storage
channel upwards or downwards in
steps of 10.



Frequency selector

Switches the indicated (inner rota-
ry switch) frequency in 25
kHz steps or the storage channel
by 1 step in each case upwards or
downwards, without carry over.

INSTALLATION AND OPERATION

AR 4201 - ()



ON/OFF switch, combined with volume control

Adjustment of volume

B. LCD (liquid crystal display) elements



(top line)

Indication of active transmission/reception frequency (active frequency).



(top line)

Transmission indication (transmission button is pressed).



(bottom line)

Indication of preset transmission/reception frequency (preset frequency).



(bottom line)

CH indication steady : indicates the storage channel.



(bottom line)

CH indication flashes : if the initiated storage operation is not completed by pressing the store key.



(bottom line)

Indication that the selected storage channel is not occupied.

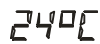

(bottom line)

Indication of temperature in °Celsius or

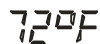

°Fahrenheit



Indication of supply voltage.



Indicating segment flashes. Supply voltage ≤ 10.5 V

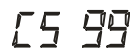

(bottom line)

Indication of scan function



(bottom line)

Indication ON



(bottom line)

Indication OFF

C. Rear of unit



BNC

50 Ohm antenna connecting sockets



25-pin D subminiature, male

Equipment connector for connecting the installation wiring

3. Operating instructions

A. Switching on the unit

CAUTION : Do not switch on the VHF transceiver when engines are being started or shutdown.

- (1) Switch on the VHF transceiver using the ON/OFF switch (rotate volume control clockwise).
- (2) The segments of the LC display will blink with the power supply voltage having dropped down to 9V d.c. Following the blinking period the self-test is conducted. With low supply voltage this test period can last up to 20 seconds. If the test is positive, the transceiver automatically switches to the mode which was activated before switch-off.

If the test result negative, the LCD will display the first fault report for approximately five seconds. If further faults were detected during test, the corresponding fault reports will be displayed additionally. After is playing the last fault report the equipment will switch automatically to the operating mode which was activated before switch-off.

- (3) The following fault signals are possible :

E1	Processor defective
E2	Synthesizer failed
E3	Fault in EE-PROM
E4	Controller (PIC) audio assembly defective

- (4) The various modes are comprehensively described, together with the setting of the equipment configuration in the service mode, in the Annex to the General Operating Instructions.

B. Transmit/receive mode

- (1) Set the frequency of the local ground station in the preset display and press the exchange key. Rotate the VOL control to the centre position.

NOTE : If the error message E2 appears in the top line during operation, the synthesizer is not latching and further R/T operations no longer possible. The VHF transceiver must be check in the next service station

INSTALLATION AND OPERATION

AR 4201 - ()

- (2) Operate the transmit button and call the ground station. Hold the microphone close to the lips for optimum speech transmission.

NOTE : The arrow in the top line of the display indicates transmit mode. During transmission a protective circuit prevents a frequency change or frequency channel change even if the frequency selector switch is rotated. The keying functions on the control panel are also inhibited.

- (3) Set the correct reception volume using the VOL control whilst the ground station is answering.

- (4) Switch on the squelch (press SQL key again). Weak reception signals and reception noises are suppressed. The switch-on threshold of the squelch can be set in the service mode.

NOTE : When changing the mode or the frequencies (PRESET- ACTIVE frequency) the change is automatically stored 2 second after the last change took place. Due to this delay changes which were made immediately before switching off the transceiver will not be memorized. Exception: Memory actions as storage by pressing the STO key.

C. Operation of intercom mode

- (1) Switch on the IC switch (external).
- (2) Operate the intercommunication (IC).
- (3) If necessary, the IC volume can be adjusted to the noise level of the aircraft (for adjustment refer to service mode).

D. Audioauxiliary input

A second and third radio unit (navigation receiver) can be monitored simultaneously via the audio auxiliary input. During transmission the auxiliary input is switched off from the audio end amplifier. If necessary, the input sensitivity can be matched to the noise level of the aircraft (for setting refer to service mode).

E. Jamming of transmit button

- (1) The VHF- transceiver is fitted with a protective circuit to protect against jamming of the transmit button or a short circuit on the key supply line. For continuous transmissions exceeding two minutes the protective circuit automatically switches from transmission to reception. This avoids the switched channel being blocked.
- (2) It is possible to activate the transmitter again immediately by re-pressing the transmit button. In the event of a fault, this is only possible after the short circuit has been cleared or the transmit button released.

CAUTION : In Stock to be able to continue transmitting even with the transmit button jammed, the VHF Transceiver must be switched off and then back on again. After that the VHF transceiver then continues to operate in the transmit mode for a further two minutes.

F. Flashing of the LCD

- (1) If the power supply for the VHF transceiver drops below 10.5 V, the display begins to flash. This flashing indicates, when operating on batteries for example, that the batteries require recharging. In practice the display begins to flash in the transmit mode because this is when the power consumption is greatest. If the power supply again increases above 10.5 V, the flashing ceases.
- (2) Because the discharge curves of the batteries are very dependant on the type of battery, e.g. lead or nickel/cadmium accumulators, and the ambient temperature also influences the discharge curves, it is not possible to state precisely how long the VHF transceiver continues to be fully functional after the LCD begins to flash.
- (3) When transmitting, the batteries can be completely discharged after a few transmission cycles but during reception functioning is still guaranteed in most cases for approximately 1 to 2 hours after the flashing begins. At 10 V supply voltage the unit still continues to function at reduced transmission power.

G. Operation of the various modes

- (1) The VHF transceiver performs various functions which are covered by individual operating modes. The mode is selected by briefly pressing the MDE key. If it is pressed for a long time (more than 1 second) this selects mode 1.

INSTALLATION AND OPERATION

AR 4201 - ()

(a) Modes:

- 1 Standard mode (display of active and preset frequency), setting the preset frequency and storing frequencies in the storage channels.
- 2 Display of the storage frequencies in the storage channels or calling up the scan function.
- 3 Display of temperature (option), power supply voltage and active frequency
- 4 Service mode, for setting the equipment configuration.

NOTE : When changing the mode or the frequencies (PRESET-ACTIVEfrequency) the change is automatically stored 2 second after the last change took place. Due to this delay changes which were made immediately before switching off the transceiver will not be memorized. Exception: Memory actions as storage by pressing the STO key.

(2) Mode 1 (standard mode)

- (a) The last displayed active and preset frequencies appear in the LCD display.

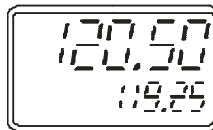

- (b) The preset frequency (bottom line) is set using the MHz and kHz frequency selector switches.
- (c) When the exchange key is pressed, a change from the active to the preset frequency occurs. A further operation of the key cancels the frequency change.

Storage operation

- (d) Pressing the STO key.
The active frequency remains displayed in the top line. The VHF transceiver is ready to transmit and receive on this frequency. The preset frequency appears flashing in the bottom line. The required frequency can be set using the kHz frequency selector (steps of 1) or the MHz frequency selector (steps of 10). Pressing the STO key.
The next free channel is shown flashing "ch". Press the STO key. The selected frequency is stored in the free speaker channel and the storage process is ended. A no memory channel is free, the highest assign memory channel is selected automatically.

or

select the channel to be overwritten using the kHz frequency selector and press the STO key. This means that this channel will be overwritten with the new frequency and the storage process ended.

Note

If no input takes place within approximately seven seconds, the VHF transceiver switches to the previously set mode.

Leaving the mode

To leave the mode, press the MDE key.

(3) Mode 2 (display of fixed frequencies in the various channels)

(a) Channel selection mode

NOTE : If in mode 2 the scan function is switched on in the service mode, no storage operation can be activated in this mode.

- 1 Select mode 2 using the MDE key. The last indicated storage channel appears in the bottom line of the LCD and the stored frequency is shown in the top line. The VHF transceiver is ready to transmit and receive on this frequency.

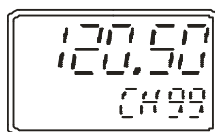

- 2 Select required channel using the kHz frequency selector (steps of 1) or the MHz frequency selector (steps of 10). Free channel (no frequency stored) will be skipped when selected.
- 3 If the Scan function is not activated, the storing function can be initiated by pressing the STO-Key. Refer to description of mode 1.

Note The top line indicates the active frequency. The active frequency indicated in the bottom line is flashing. Select the desired frequency can be set using the kHz frequency selector or the MHz frequency selector.

- 4 Exit from mode 2 is achieved by pressing the MDE key.

(b) Scan function

Note: When operating the scan mode observe the regulations for the aviation radio service

- 1 If the scan function is activated in the equipment configuration, pressing the STO key changes from the channel selection mode to the scan function. In the scan function, the frequency appears in the top line of the display and the associated channel with the preset CS is shown in the bottom line.
- 2 In the scan function, either all the occupied storage channels or a required range of storage channels can be scanned. The scanning range is specified in the service mode. The various storage channels are scanned in 200 ms intervals. If the microprocessor finds a carrier in one of the channels, it holds a short on this channel and checks whether an evaluatable signal is present. If no evaluatable signal is present, it switches to the next channel and then reverts to the 400 ms intervals (milliseconds range). In the event of an evaluatable reception signal being received the VHF transceiver remains on the storage channel until an evaluatable reception signal is no longer present. After a hold time 0 to 60 seconds (can be set in the service mode) the scanning of the storage channels at 200 ms intervals begins again. The set squelch level is the criterium for an evaluatable reception signal, regardless of whether the squelch is activated or not.
- 3 The VHF transceiver is equipped with channel priority. This function can be switched ON or OFF in service mode SF 18

NOTE: If an adequate signal is required on the priority channel with option channel priority switched ON, the VHF transceiver automatically leaves the SCAN mode and is ready for transmission and receive on this channel. For return to the SCAN mode, again press the STO key.

- 4 The scan function is terminated by pressing the STO key. The VHF transceiver then begins to operate again in the channel selection mode - the CS in the bottom line goes out and CH appears. Exit from mode 2 is accomplished in the same way as described in the channel selection mode.

- (4) Mode 3 Indication of supply voltage or temperature (option)



When the exchange key is pressed, a change from the supply voltage and temperature indication occurs.

NOTE : If no temperature sensor is connected, this mode is skipped when the exchange key is pressed.

- (a) The supply voltage and temperature is continuously measured. Indication occurs only in mode 3. The mode is selected by briefly pressing the MDE key once or several times (corresponding to the previous state) the active frequency on which the VHF transceiver is ready for operation is shown in the top line and the measured voltage/temperature is displayed in the bottom line. The display in °C or °F can be set in the service mode.
- (b) The active frequency (top line) can be changed using both frequency selector switches. A storage operation is activated using the STO key. This procedure is described in mode 1.
- (c) To exit mode 3 it is necessary to press the MDE key.

INSTALLATION AND OPERATION

AR 4201 - ()

(5) Service mode (equipment configurations)

The service mode is meant to enable the ground technicians to set the equipment configuration and must not be used in flight.

(a) The following settings can be changed or set:

SqL	Setting the switch-on threshold of the squelch
SIdE	Setting the sidetone volume
aU	Setting the audio auxiliary volume
IC	Setting the IC volume
SF5	Calibrating the temperature sensor
SF6	Setting the addressable storage locations
SF7	Setting the temperature display in °C or °F
SF8	Switching on the scan function
SF9	Setting the hold time after completion of a call in the scan mode
SF10	Release the frequency setting (channel selection only)
SF11	Release the frequency storage
SF12	Erasure of stored frequencies
SF13	Setting the "channel start" of the scanning range
SF14	Setting the "channel end" of the scanning range
COdE	Entering a password to interlock the equipment configuration.
SF16	Dynamic mike input sensitivity
SF17	Inhibiting the transmit mode for one or more memory channel
SF18	Channel priority ON/OFF switch (option)
FSqL	No function
SF20	Speaker muting switch ON/OFF
SF21	Increase the audio power output
- . -	Indication the software version and change status

NOTE : The equipment configuration SqL, SIdE, AU, IC and SF16 settings given in the service mode are set by the factory as basic settings using standard values. If reversion to the standard values is required, the portable VHF Transceiver must be switched off and switched on again simultaneously pressing the STO and MDE keys. This does not overwrite the password.

If no temperature sensor is connected, the mode SF5 and SF 7 is skipped when the mode key is pressed.

If the SF8 scan function is not activated, than the function SF9, SF13 and SF14 will not be displayed.

The settings SF 17 and SF 18 are optionen. When the optionen are not activated, the mode SF17 and SF 18 is skipped when the mode key is pressed.

INSTALLATION AND OPERATION

AR 4201 - ()

(b) Calling up the service mode

Switch off the VHF transceiver. Hold the mode key (MDE) pressed and at the same time switch on the unit. The VHF transceiver switches to the service mode without a unit test. SqL appears in the top line and the switch on threshold of the squelch is shown on the bottom line.

NOTES :

- The settings are selected in steps by briefly pressing the MDE key in the service mode. If the MDE key is pressed at the end of the setting, the setting SqL then appears. If a direct return to the SqL setting is required the MDE key must be pressed for at least one second.
- If settings are not activated, (e.g. scan function) this mode is skipped by pressing the mode key.
- In the service mode the VHF transceiver operates independently of the settings on the control panel, on the frequency which was last set as the active frequency. Wenn the PTT-Key is pressed in the service mode, the display indicates in the top line the active frequency
- The user can interlock his equipment configuration settings with the aid of a password. The VHF transceiver is delivered from the factory without a password. Section COdE "Entry of password for interlocking the equipment configuration" describes how to enter a password.

1 Setting the squelch threshold

a If function SqL is called up, the following displays appear.

Top line	SqL	
Bottom line	00 to 200	Standard value 130
	(HI sensitivity LO)	

b By means of the kHz switch, the squelch threshold can be altered upwards or downwards in steps of 5. The set value is stored by pressing the STO key.

INSTALLATION AND OPERATION

AR 4201 - ()

2 Setting the sidetone level

- a Call up the SIdE function using the MDE key. The following displays appear.

Top line	SIdE	
Bottom line	00 to 63 (LO level HI)	Standard value 32

- b Using the kHz switch, The sidetone level can be altered upwards or downwards. The set value is stored by pressing the STO key.

Upwards serial No.: 1500 Press the PTT key and set the correct sidetone volume using the kHz switch. The sidetone level can be altered upwards or downwards. The set value is stored by pressing the STO key.

3 Setting the audio auxiliary level

- a Call up the AU function using the MDE key. The following displays appear.

Top line	AU	
Bottom line	00 to 63 (LO level HI)	Standard value 63

- b Using the kHz switch, alter the audio auxiliary level upwards or downwards. The set value is stored by pressing the STO key.

4 Setting the IC level

- a Call up the IC function using the MDE key. The following displays appear :

Top line	IC	
Bottom line	00 to 63 (LO level HI)	Standard value 32

- b The IC level can be changed upwards or downwards using the kHz switch. The set value is stored by pressing the STO key.

INSTALLATION AND OPERATION

AR 4201 - ()

- 5 Calibrating the temperature sensor
- a If no temperature sensor is connected, this mode is skipped when the mode key is pressed.
 - b Calibration is only necessary if the sensor has been retrospectively fitted or replaced.
 - c After calling up using the MDE key, the following display appears.

Top line	SF 5
Bottom line	Measured temperature
 - d Measure the ambient air temperature of the sensor by means of a suitable thermometer and set temperature display on the LCD. To this measured value by means of the kHz frequency selector. The entry is stored by pressing the STO key and of the temperature sensor is calibrated .
- 6 Setting addressable storage locations 1 to 99.
- a Call up the function using the MDE key. The following display then appears.

Top line	SF 6
Bottom line	1 to 99
 - b The number of the storage channel between 1 to 99 can be selected as required using the kHz switch and stored by pressing the STO key. If the number of storage channels is limited and if channels outside the limited area have already been used, these can no longer be called up. The data in the channels outside the area continues to remain stored and it can be re-used at any time by lifting the restricted area.
- 7 Setting the temperature display in the °C or °F.
- a If no temperature sensor is connected, this mode is skipped when the mode key is pressed.
 - b Call up function SF 7 using the MDE key. The following displays appear :

Top line	SF 7
Bottom line	°C of °F
 - c The required display is selected using the kHz switch and the selection is stored by pressing the STO key.

INSTALLATION AND OPERATION

AR 4201 - ()

- 8 Switching on the scan function
- a If the SF8 scan function is not activated, than the function SF9, SF13 and SF14 will not be displayed.
 - b Call up function SF 8 using the MDE key. The following display appears.

Top line	SF 8
Bottom line	OFF or On
 - c Select the required function using the kHz switch and store the selection by pressing the STO key.

OFF = scan function off

On = scan function on
- 9 Setting the hold time in the scan function (only displayed, if SF8 is activated).
- a Call up function SF 9 using MDE key. The following displays appear :

Top line	SF 9
Bottom line	0 .0 to 60.0
 - b The hold time can be set as required between 0,0 ..0,9 seconds using the kHz seletor switch and between 0..60 seconds using the MHz selector switch. The set value is stored by pressing the STO key.
- 10 Inhibiting the frequency setting (channel selection only).
- a Call up function SF 10 using the MDE key. The following displays appear :

Top line	SF 10
Bottom line	OFF or On
 - b Select the required function using the kHz key and store the function by pressing the STO key.

OFF= Frequency setting not possible. The VHF transceiver can only work on the frequencies stored in the individual channels.
On = Frequency setting possible (standard setting).

INSTALLATION AND OPERATION

AR 4201 - ()

11 Inhibiting the frequency storage

- a Call up function SF 11 using the MDE key. The following display appears.

Top line SF 11

Bottom line OFF or On

- b Select the required function using the kHz switch and store the selection by pressing the STO key.

OFF = The storage of frequencies in the individual channels is not possible. The VHF transceiver can only work on the set frequency.

On = Storage of frequencies in the individual channels is possible (standard setting)

12 Erase stored frequencies

- a Call up function SF 12 using the MDE key. The following display appears.

Top line SF 12

Bottom line CH channel number

- b Select the channel to be erased using the kHz (steps of 1) or MHz (steps of 10) switch. The stored frequency is erased by pressing the STO key.

13 Setting the "channel start" scanning range (only displayed, if SF8 is activated).

- a Call up function SF 13 using the MDE key. The following displays appear :

Top line SF 13

Bottom line CS channel number

- b Select the starting channel, using the kHz (steps of 1) or MHz (steps of 10) switch, at which the scan function is to begin. The starting channel is stored by pressing the STO key.

Note

When this function is set OFF, the active and preset frequencies which were set last remains are available in Mode 1

INSTALLATION AND OPERATION

AR 4201 - ()

- 14 Setting the "channel end" scanning range.(only displayed, if SF8 is activated).
- a Call up function SF 14 using the MDE key. The following displays appear :
- | | |
|-------------|-------------------|
| Top line | SF 14 |
| Bottom line | CS channel number |
- b Using the kHz (steps of 1) or MHz (steps of 10) switch, select the end channel at which the scan function is to stop. Store the end channel by pressing the STO key.

- 15 Entry of password to interlock the equipment configuration.
- a Call up the COdE function using the MDE key. The following display appears.
- | | |
|-------------|---------|
| Top line | COdE 15 |
| Bottom line | 0 |
- b Set any 4-digit numerical code using the kHz (steps of 1) or MHz (steps of 10) switch. Store the numerical code by pressing the STO key.

NOTE : As soon as a password is given an 0 appears in the bottom line when the service mode is called up. The numerical code must then be input using the MHz or kHz switch. If the VHF transceiver detects a false numerical code, it automatically switches to the last mode. If the password is to be erased or changed, this is done by calling up the service mode using the old password. The COdE function is then chosen and either an 0 is entered everywhere or the changed numerical code is entered.

- 16 Setting the dynamic mike input sensitivity
- a Call up function SF 16 using the MDE key. The following displays appears :
- | | |
|-------------|---|
| Top line | SF 16 |
| Bottom line | 00 bis 63 Standard value 32
(LO sensitivity HI) |
- b The dynamic mike input sensitivity can be changed upwards or down-wards using the kHz switch. The set value is stored by pressing the STO key.

- 17 Inhibiting the transmit mode for one or more memory channel (option)
- a Call up function SF 17 using the MDE key. The following displays appears :
- | | |
|-------------|-------------------|
| Top line | SF 17 |
| Bottom line | CS channel number |
- b Using the kHz (steps of 1) or MHz (steps of 10) switch, select the desired channel for inhibiting the transmit mode. Store the channel by pressing the STO key. Several channels can be selected on priority channels. The letter T appears in the bottom line before CS. When the STO key is pressed again, the inhibiting transmit mode is canceled. The letter T is not appears in the bottom line before CS.
- 18 Channel priority ON/OFF switch (Option)
- a Call up function SF 18 using the MDE key. The following displays appears :
- | | |
|-------------|-------------------|
| Top line | SF 18 |
| Bottom line | CS channel number |
- b Using the kHz (steps of 1) or MHz (steps of 10) switch, select the desired channel. Store the channel by pressing the STO key. Several channels can be selected on priority channels.
- 19 FSqL no function
- 20 Speaker muting switch ON/OFF
- a Call up function using the MDE key. The following displays appears :
- | | |
|-------------|-----------|
| Top line | SF20 |
| Bottom line | OFF or On |
- OFF = Speaker muting on
On = Speaker always switched on
- b Select the function using the kHz switch. Store the required function by pressing the STO key. This selection becomes active after ending the service mode.

4. Safety instructions

The following instructions must be followed for safe operation of the VHF transceiver:

- A. Switch off the unit when starting or shutting down engines.
- B. A speech test is to be performed before start up and it should be noted that if the speech test is carried out close to the ground station the results may be positive even if the antenna cable is broken or short-circuited. At a distance of 5 to 10 km no connection will be made.
- C. Use a loud voice for speech communication and hold the microphone close to the lips. Otherwise cabin noise can be intrusive and make understanding difficult.
- D. Use only microphones or headsets which are suitable for use in aircraft. In aircraft made of wood or synthetic materials or in gliders or helicopters, incoming radiation on the equipment antenna can affect the integrated amplifier of the microphone (feedback). This is noticeable in the ground station by whistling and/or heavy distortion. The described disturbances can occur in different ways on the different transmission channels.
- E. Transmit buttons can stick and cause continuous transmission. Therefore, when transmitting ensure that the arrow in the top line on the left next to the active frequency display disappears when the transmission button is released.

BECKER
AVIONIC SYSTEMS

INSTALLATION AND OPERATION

AR 4201 - ()

Blank